

# HCF

中实四爪卡盘

## 4-Jaw Closed-Center Chuck



■ 4-jaw wedge-style closed-center power chuck

■ 四爪楔形闭心式卡盘

### HYDRAULIC CHUCK

See page 60-67  
Gripping Force

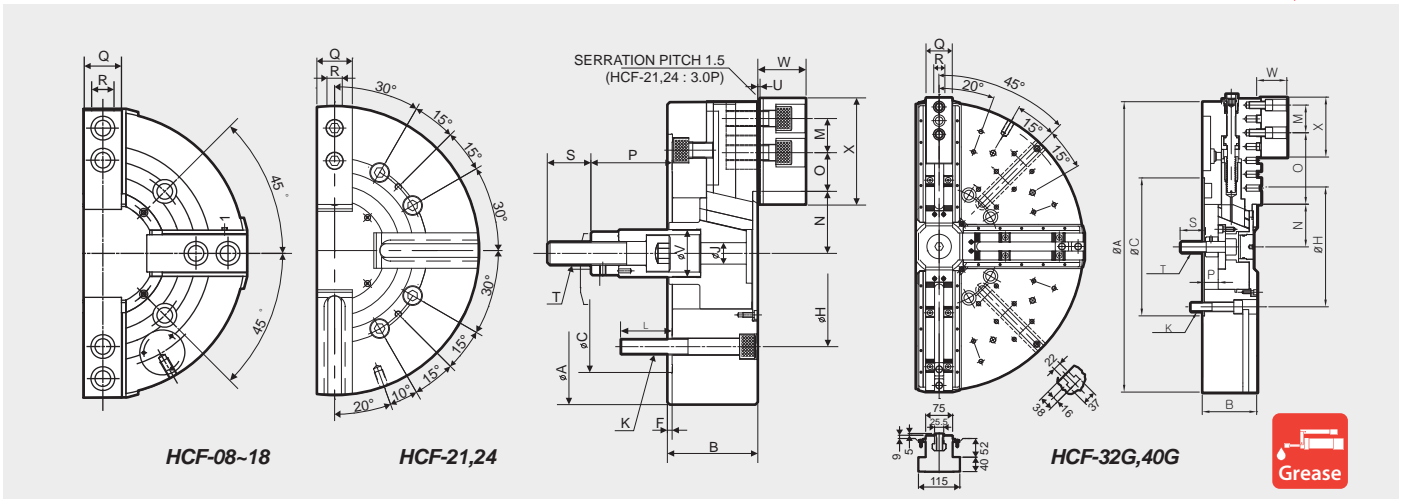

It is recommended to grease chucks at least twice a day in order to maximize longevity.  
为了延长寿命 建议一天润滑2次。

### Dimensions

	ΦA	B	ΦC(H6)	F	ΦH	ΦJ	K	L	M	Nmax.	Nmin.	Omax.	Omin.	Pmax.	Pmin.	Q	R	S	T	U	ΦV	W	X
HCF-08	210	85	170	5	150	25	6-M12	30	25	46.3	41.9	22.25	11.75	125	106	35	14	36	M20x2.5	5	38	42	95
HCF-12	304	106	220	6	171.4	34	4-M16	38	30	61	55.7	48.75	12.75	163	133	49	18	36	M20x2.5	5	50	53.5	129
HCF-15	381	114	300	6	235	27	4-M20	65	43	78	70	48.75	23.25	104	69	50	26	55	M30x3.5	2	60	61	135
HCF-18	450	114	300	6	235	27	4-M20	30	43	108	100	48.75	23.25	92	57	50	26	55	M30x3.5	2	60	60	135
HCF-21	530	125	380	6	330.2	27	8-M22	61	60	86	78	93.5	27.5	97	62	65	25	55	M30x3.5	3	60	70	180
HCF-24	610	150	380	6	330.2	27	8-M22	31	60	125	117	93.5	27.5	97	62	65	25	55	M30x3.5	3	60	70	180
HCF-32G	800	150	380	6	330.2	65	8-M24x120L	41	76.2	117.6	102.7	196.9	44.5	35	-3	75	25.5	70	M30x3.5	5	102	82	165
HCF-40G	1000	180	520	8	463.6	32	8-M20x160L	32	76.2	217.3	194.3	91.1	14.9	-25	32	110	30	65	M36x4.0	4	52	106	270

※ Blank and machined draw-nuts are available.

※ HCF-21 and HCF-24 are available with M22 or M24 mounting bolts.

※ Groove type is standard model on HCF-32G and HCF-40G.

※ 最大转速基于实际测量。

※ 技术规格若发生改变，恕不另行通知。

※ HCF-12可用于长行程。

### Specifications

Type	Jaw Stroke Dia. 卡爪冲程直径 [mm]	Plunger Stroke 柱塞冲程 [mm]	Grip Dia. 通孔直径 Max. [mm] Min. [mm]		Max. Permissible Input Force 允许输入力 [kN(kgf)]	Max. Static Gripping Force 最大静态支持力 [kN(kgf)]	Max. R.P.M. 最大转速 [min <sup>-1</sup> (r.p.m.)]	Weight 重量 [kgf]	GD <sup>2</sup> 容许工作惯性 [N·m <sup>2</sup> (kg·m <sup>2</sup> )]	Max. Hydraulic Pressure 最大液压压力 Mpa(kgf/cm <sup>2</sup> )	Operating Cylinder 工作缸	Operating Hard Jaw 北川型号
HCF-08	8.8	19	210	17	16.5(1638)	50(5099)	4000	22	5.20(0.53)	1.6(16.3)	Y-1225R(RE)	HB08A1
HCF-12	10.5	30	304	26	27.5(2804)	104(10605)	3000	55	27.7(2.83)	1.8(18.4)	Y-1530R(RE)	HB12B1
HCF-15	16	35	381	71	54.6(5575)	165.8(16927)	3040	98	72.6(7.4)	2.13(21.7)	Y-2035R(RE)	HB15N1
HCF-18	16	35	450	133	54.6(5575)	165.8(16927)	2710	124	92.2(9.4)	2.13(21.7)	Y-2035R(RE)	HB15N1
HCF-21	16	35	530	62	54.6(5575)	168(18550)	1700	180	188.3(19.2)	2.13(21.7)	Y-2035R(RE)	HB18B2
HCF-24	16	35	610	152	54.6(5575)	183(18550)	1500	223	271.7(27.7)	2.13(21.7)	Y-2035R(RE)	HB18B2
HCF-32	30	38	800	85	88(8925)	156(15821)	800	350	601(61)	3(30.6)	Y-2050RE	HB32SB2
HCF-40	46	57	1000	150	120(12245)	213(21769)	630	620	1720(174.5)	2.7(27.2)	Y-2560RE	HB40SB2

※ Maximum turning speed is based upon actual measurement.

※ Specifications are subject to change without notice.

※ HCF-12 is also available with long stroke.

※ 最大转速基于实际测量。

※ 技术规格若发生改变，恕不另行通知。

※ HCF-12可用于长行程。