

# HCT 中实两爪卡盘

## 2-Jaw Closed-Center Chuck



■ 2-jaw wedge-style power chuck

■ 两爪楔形动力卡盘带大抓握力

### HYDRAULIC CHUCK

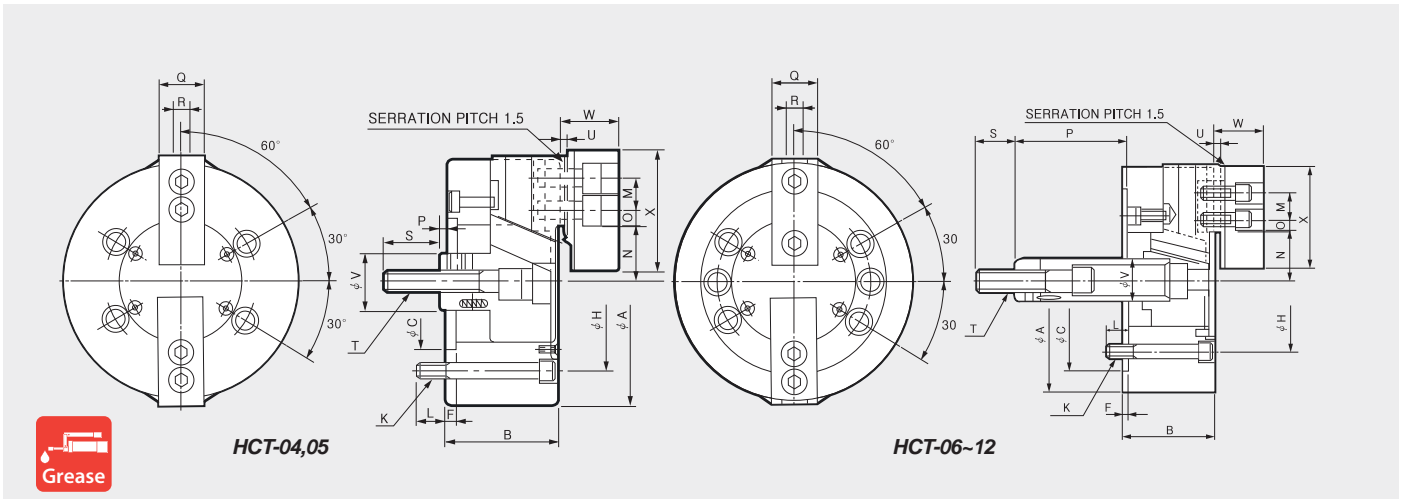

It is recommended to grease chucks at least twice a day in order to maximize longevity.  
为了延长寿命 建议一天润滑2次。

### Dimensions

	ΦA	B	ΦC(H6)	F	ΦH	K	L	M	Nmax.	Nmin.	Omax.	Omin.	Pmax.	Pmin.	Q	R	S	T	U	ΦV	W	X
HCT-04	110	52	60	6	80	4-M8x55	12	14	23.3	20.1	11.25	8.75	17	3	23	10	25	M10x1.5	3	26	27	55
HCT-05	135	55	80	7	100	4-M8x60	14	19	30.4	27.2	11.25	6.75	6	-8	23	10	35	M12x1.75	3	28	29	62
HCT-06	165	74	140	5	104.8	6-M10x70	14	20	37.8	33.55	13.75	7.75	100	81.5	31	12	36	M16x2.0	4	34	35	72
HCT-08	210	85	170	5	133.4	6-M12x85	20	25	46.3	41.9	22.25	11.75	125	106	0.35	14	36	M20x2.5	5	38	42	95
HCT-10	254	89	220	5	171.4	6-M16x85	18	30	51.1	46.7	30.75	11.25	158	133	40	16	36	M20x2.5	5	45	46	110
HCT-12	304	106	220	6	171.4	6-M16x100	18	30	61	55.75	48.75	12.75	163	133	49	18	36	M20x2.5	5	50	53.5	129

### Specifications

Type	Jaw Stroke Dia. 卡爪冲程直径 [mm]	Plunger Stroke 柱塞冲程 [mm]	Grip Dia. [mm] 通孔直径 Max. Min.	Max. Permissible Input Force 允许输入力 [kN(kgf)]	Max. Static Gripping Force 最大静态夹持力 [kN(kgf)]	Max. R.P.M. 最大转速 [min-1(r.p.m.)]	Weight 重量 [kgf]	GD <sup>2</sup> 容许工作惯性 [N-m <sup>2</sup> (kgf-cm <sup>2</sup> )]	Max. Hydraulic Pressure 最大液压力 [Mpa(kgf/cm <sup>2</sup> )]	Operating Cylinder 工作缸 [Hydraulic]	KITAGAWA® Model 北川型号
HCT-04	6.4	14	110 5	5.3(540)	15.2(1550)	6000	3.8	0.26(0.027)	1.68(17.1)	Y-0715R	NT-04
HCT-05	6.4	14	135 16	5.3(540)	16.9(1713)	5500	5.8	0.59(0.06)	1.68(17.1)	Y-0715R	NT-05
HCT-06	8.5	18.5	165 14	12(1224)	35(3569)	5000	11.4	1.67(0.17)	1.7(17.3)	Y-1020R	NT-06
HCT-08	8.8	19	210 17	16.5(1683)	50(5099)	4000	22	5.20(0.53)	1.6(16.3)	Y-1225R	NT-08
HCT-10	8.8	25	254 22	19.5(1988)	72(7342)	3500	31.6	11.5(1.17)	1.9(19.4)	Y-1225R	NT-10
HCT-12	10.5	30	310 22	27.5(2804)	104(10605)	3000	55	27.8(2.83)	1.8(18.4)	Y-1530R	NT-12

※ Maximum turning speed is based upon actual measurement.

※ Specifications are subject to change without notice.

※ Samcully Machinery Co., Ltd. is no longer an OEM manufacturer for Kitagawa® Iron Works Co., Ltd.

※ 最大转速基于实际测量。

※ 技术规格若发生改变，恕不另行通知。

※ 三千里机械已结束与日本北川OEM生产。