

HC-A 中实标准三爪卡盘带安装盘

3-Jaw Closed-Center Chuck with Adaptor (165mm - 304mm)



- 3-jaw wedge-type closed-center power chuck with adaptor

- 三爪楔形闭心式卡盘带安装盘

HYDRAULIC CHUCK

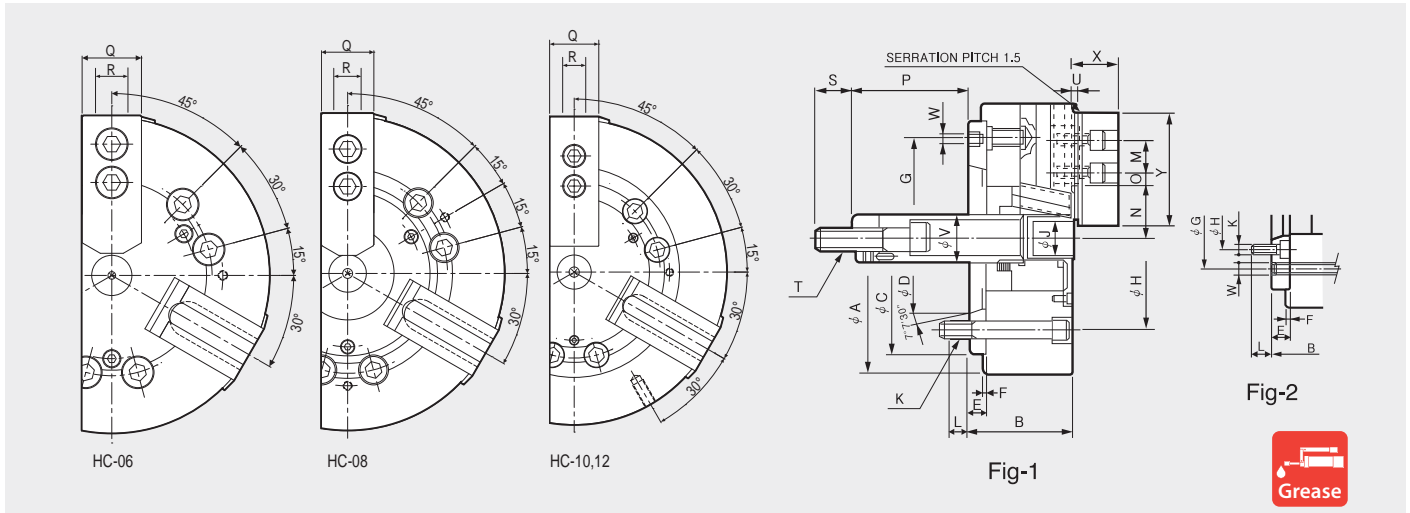

It is recommended to grease chucks at least twice a day in order to maximize longevity.
为了延长寿命 建议一天润滑2次。

Dimensions

	ΦA	B	ΦC(H6)	ΦD	E	F	ΦG	ΦH	ΦJ	K	L	M	Nmax.	Nmin.	Omax.	Omin.	Pmax.	Pmin.	Q	R	S	T	U	ΦV	W	X
HC-06A05	165	84	140	82.563	15	5	116	104.8	21	6-M10	14	20	37.8	33.5	13.75	7.75	83	64.5	31	12	358	M16x2.0	4	34	3-M6	35
HC-08A06	210	97	170	106.375	17	5	150	133.4	25	6-M12	18	25	46.3	41.9	22.25	11.75	92(108)	73(89)	35	14	36	M20x2.5	5	38	3-M6	42
HC-10A06	254	109	220	106.375	25	5	171.4	133.4	34	6-M12	18.5	30	51.1	46.7	30.75	11.25	84(128)	74(89)	40	16	36	M20x2.5	5	45	6-M16	46
HC-10A08	254	102	220	139.719	18	5	190	171.4	34	6-M16	25	30	51.1	46.7	30.75	11.25	101(140)	76(115)	40	16	36	M20x2.5	5	45	3-M8	46
HC-12A06	304	125	220	106.375	25	6	171.4	133.4	34	6-M12	18	30	61	55.75	48.75	12.75	117(138)	87(108)	49	18	36	M24x3.0(M20x2.5)	5	50	6-M16	53.5
HC-12A08	304	118	220	139.719	18	6	190	171.4	34	6-M16	25	30	61	55.75	48.75	12.75	124(145)	94(115)	49	18	36	M24x3.0(M20x2.5)	5	50	3-M8	53.5

- ※ Blank and machined draw-nuts are available.
- ※ "U" is Max. Draw nut size.

() 括号里头的尺寸将设计更改后适用于卡盘

Specifications

Type	Spindle Nose No.	Jaw Stroke Dia.	Plunger Stroke	Grip Dia. [mm]		Max. Permissible Input Force	Max. Static Gripping Force	Max. R.P.M.	Weight	GD ²	Max. Hydraulic Pressure	Operating Cylinder		Operating Hard Jaw	KITAGAWA® Model
				Max.	Min.							[Hydraulic]	[Pneumatic]		
HC-06A05	A2-5	8.5	18.5	165	19	18(1835)	52.5(5353)	5270	14	1.96(0.20)	2.6(26.5)	Y-1020R(RE)	AY-1720R	HB06A1	N-06A05
HC-08A06	A2-6	8.8	19	210	23	25(2549)	75(7648)	4760	27	5.79(0.59)	2.5(25.5)	Y-1225R(RE)	AY-2225R	HB08A1	N-08A06
HC-10A06	A2-6	8.8	25	254	24	29(2957)	108(11013)	4010	40	13.14(1.34)	2.8(28.6)	Y-1225R(RE)	AY-2225R	HB10A1	N-10A06
HC-10A08	A2-8	8.8	25	254	224	29(2957)	108(11013)	4010	40	12.84(1.31)	2.8(28.6)	Y-1225R(RE)	AY-2225R	HB10A1	N-10A08
HC-12A06	A2-6	10.5	30	304	26	41(4181)	156(15907)	3380	67	29.82(3.04)	2.7(27.5)	Y-1530R(RE)	AY-2730R	HB12A1	N-12A06
HC-12A08	A2-8	10.5	30	304	26	41(4181)	156(15907)	3380	66	29.52(3.01)	2.7(27.5)	Y-1530R(RE)	AY-2730R	HB12A1	N-12A08

- ※ Refer to Fig-2 for HC-10A06 and HC-12A06.
- ※ Maximum turning speed is based upon actual measurement.
- ※ Specifications are subject to change without notice.
- ※ Samcully Machinery Co., Ltd. is no longer an OEM manufacturer for Kitagawa® Iron Works Co., Ltd.

- ※ HC-10A06, HC-12A06 见 图-2.
- ※ 最大转速基于实际测量。
- ※ 技术规格若发生改变，恕不另行通知。
- ※ 三千里机械已结束与日本北川OEM生产。

HC-A

中实标准三爪卡盘带安装盘

3-Jaw Closed-Center Chuck with Adaptor (381mm - 610mm)



- 3-jaw wedge-type closed-center power chuck with adaptor

- 三爪楔形闭心式卡盘带安装盘

HYDRAULIC CHUCK

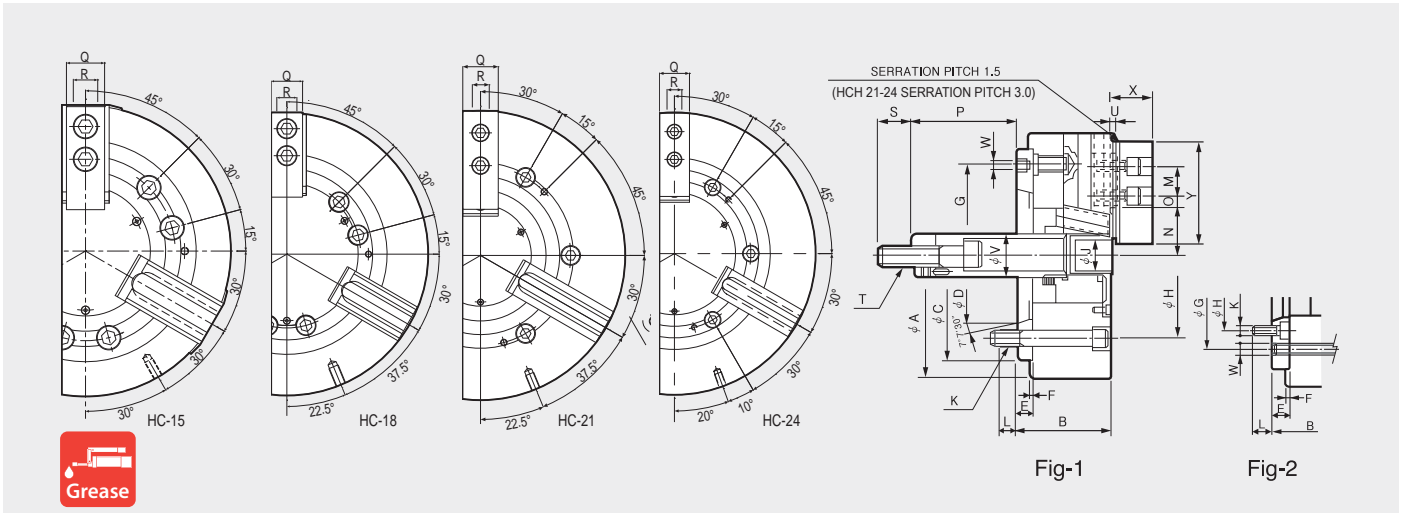

It is recommended to grease chucks at least twice a day in order to maximize longevity.
为了延长寿命 建议一天润滑2次。

Dimensions

	ΦA	B	ΦC(H6)	ΦD	E	F	ΦG	ΦH	ΦJ	K	L	M	Nmax.	Nmin.	Omax.	Omin.	Pmax.	Pmin.	Q	R	S	T	U	ΦV	W	X
HC-15A08	381	141	300	139.719	33	6	235	171.4	27	6-M16	24	43	77.5	69.5	48.75	23.25	71	36	50	25.5	55	M30x3.5	2	60	6-M20	61
HC-15A11	381	130	300	196.869	22	6	260	235	27	6-M20	33	43	77.5	69.5	48.75	23.25	82	47	50	25.5	55	M30x3.5	2	60	3-M10	61
HC-18A08	450	141	300	139.719	33	6	235	171.4	27	6-M16	24	43	108	100	48.75	23.25	59	24	50	25.5	55	M30x3.5	2	60	6-M20	61
HC-18A11	450	130	300	196.869	22	6	260	235	27	6-M20	33	43	108	100	48.75	23.25	70	35	50	25.5	55	M30x3.5	2	60	3-M10	61
HC-21A11	530	161	380	196.869	42	6	330.2	235	27	6-M20	29	60	86	78	93.5	27.5	55	20	65	25	55	M30x3.5	3	60	6-M22	70
HC-21A15	530	146	380	285.775	27	6	330.2	330.2	27	6-M22	34	60	86	78	93.5	27.5	70	35	65	25	55	M30x3.5	3	60	3-M12	70
HC-24A11	610	161	380	196.869	42	6	330.2	235	27	6-M20	29	60	125	117	93.5	27.5	55	20	65	25	55	M30x3.5	3	60	6-M22	70
HC-24A15	610	146	380	285.775	27	6	330.2	330.2	27	6-M22	34	60	125	117	93.5	27.5	70	35	65	25	55	M30x3.5	3	60	6-M12	70

Specifications

Type	Spindle Nose No.	Jaw Stroke Dia.	Plunger Stroke	Grip Dia. [mm]	Max. Permissible Input Force	Max. Static Gripping Force	Max. R.P.M.	Weight	GD ²	Max. Hydraulic Pressure	Operating Cylinder	Operating Hard Jaw	KITAGAWA® Model
	心轴鼻端编号	卡爪冲程直径	柱塞冲程	通孔直径	允许输入力	最大静态夹持力	最大转速	重量	容许工作惯性	最大液压压力	工作缸	工作硬爪	北川型号
		[mm]	[mm]	Max. Min.	[kN(kgf)]	[kN(kgf)]	[min-1(r.p.m.)]	[kgf]	[N·m ² (kgf·m ²)]	[Mpa(kgf/cm ²)]	[Hydraulic] [Pneumatic]		
HC-15A08	A2-8	16	35	381 71	82(8362)	249(25391)	3040	105	76.49(7.8)	3.2(32.6)	Y-2035R(RE)	-	HB15N1 N-15A08
HC-15A11	A2-11	16	35	381 71	82(8362)	249(25391)	3040	103	73.55(7.5)	3.2(32.6)	Y-2035R(RE)	-	HB15N1 N-15A08
HC-18A08	A2-8	16	35	450 133	82(8362)	249(25391)	2710	134	97.08(9.9)	3.2(32.6)	Y-2035R(RE)	-	HB15N1 N-18A11
HC-18A11	A2-11	16	35	450 133	82(8362)	249(25391)	2710	131	95.12(9.7)	3.2(32.6)	Y-2035R(RE)	-	HB15N1 N-18A11
HC-21A11	A2-11	16	35	530 62	82(8362)	273(27838)	1940	198	201.03(20.5)	3.2(32.6)	Y-2035R(RE)	-	HB18B2 N-21A11
HC-21A15	A2-15	16	35	530 62	82(8362)	273(27838)	1940	190	194.15(19.9)	3.2(32.6)	Y-2035R(RE)	-	HB18B2 N-21A15
HC-24A11	A2-11	16	35	610 152	82(8362)	273(27838)	1760	241	289.28(29.5)	3.2(32.6)	Y-2035R(RE)	-	HB18B2 N-24A11
HC-24A15	A2-15	16	35	610 152	82(8362)	273(27838)	1760	234	276.54(28.2)	3.2(32.6)	Y-2035R(RE)	-	HB18B2 N-24A15

※ Maximum turning speed is based upon actual measurement.

※ Specifications are subject to change without notice.

※ Refer to Fig-2 for HC-15A08, HC-18A08, HC-21A11, HC-24A11.

※ Samcully Machinery Co., Ltd, is no longer an OEM manufacturer for Kitagawa® Iron Works Co., Ltd.

※最大转速基于实际测量。

※技术规格若发生改变，恕不另行通知。

※ HC-15A08, HC-18A08, HC-21A08, HC-21A11, HC-24A11 見圖-2。

※三千里机械已结束与日本北川OEM生产。