

MH 大通孔中空卡盘

Standard Mega Bore 3-Jaw High-Speed Open-Center Chuck



- Mega-bore 3-jaw wedge-style
- open-center power chuck
- 大孔径三爪楔形开中心式动力卡盘

HYDRAULIC CHUCK

See page 60-67
Gripping Force

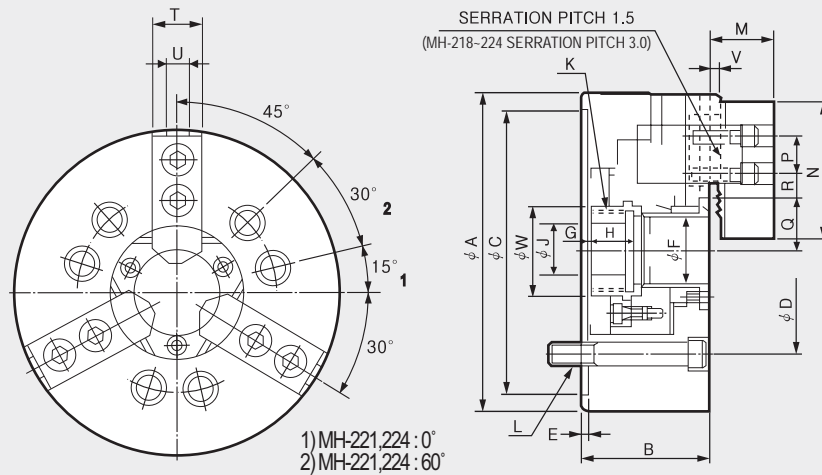

It is recommended to grease chucks at least twice a day in order to maximize longevity.
为了延长寿命 建议一天润滑2次。

Dimensions

	ΦA	B	ΦC(H6)	ΦD	E	ΦF	Gmax.	Gmin.	H	ΦJ	Kmax.	L	M	N	P	Qmax.	Qmin.	Rmax.	Rmin.	T	U	V	ΦW
MH-206	175	81	140	104.8	5	52	14	-1	17.5	20	M60x2.0	3-M10x95	33	72	20	38	34.8	21.75	10.25	31	12	2	65
MH-208	210	91	170	133.4	5	66	7.5	-10	27	30	M75x2.0	6-M12x115	39	95	25	45.7	42	23.75	11.75	35	14	2	80
MH-210	254	100	220	171.4	5	82	8.5	-10.5	25	52	M90x2.0	6-M16x120	43	110	30	54.5	50.1	32.25	14.25	40	16	2	101
MH-212	315	110	300	235	6	103	8	-15	28	82.5	M116x2.0	6-M20x130	51	111	30	67.3	62	45.75	15.75	49	21	2	124
MH-218	457	135	380	300.2	6	166.5	8	-23	50	107	M175x3.0	6-M20x130	69	165	50	102	96.25	58.25	20.25	69	22	5	186
MH-221	530	140	380	330.2	6	166.5	11	-12	39	80	M180x3.0	6-M22x140	73	180	60	111.75	106.5	72.5	21.5	65	25	5	197
MH-224	610	149	380	330.2	6	190	20	-3	40.5	80	M200x3.0	6-M22x150	73	180	60	119.5	114.2	105.5	21.5	65	25	5	210

※ Blank and machined draw-nuts are available.
※ "K" is Max. Draw nut size.

※ 提供毛坯和机加拉力螺母。
※ "K" 是拉杆螺母(Draw Nut)最大值。

Specifications

Type	Thru Hole Dia. 通孔直径 [mm]	Grip Dia. [mm] 通孔直径 Max. Min.	Jaw Stroke Dia. 卡爪冲程直径 [mm]	Plunger Stroke 柱塞冲程 [mm]	Max. Permissible Input Force 允许输入力 [kN(kgf)]	Max. Static Gripping Force 最大静态夹持力 [kN(kgf)]	Max. R.P.M. 最大转速 [min ⁻¹ (r.p.m.)]	Weight 重量 [kgf]	GD ² 容许工作惯性 [N·m ² (kgf·m ²)]	Operating Cylinder 工作缸	Max. Hydraulic Pressure 最大液压力 [Mpa(kgf/cm ²)]	Operating Hard Jaw 工作硬爪	KITAGAWA® Model 北川型号
MH-206	52	175 16.5	6.4	15	24.7(2551)	57.3(5847)	6000	11.9	2.26(0.23)	SH-15052 (SYH-1552)	1.78(18.1)	HB06A1	-
MH-208	66	210 23	7.4	17.5	36.4(3596)	87(8872)	5000	23	5.6(0.57)	SH-17068 (SYH-1768)	2.34(23.9)	HB08A1	-
MH-210	82	254 30	8.8	19	49(4976)	126.6(12848)	4500	32	12.37(1.26)	SH-19082	2.74(28)	HB10A1	-
MH-212	103	315 54	10.6	23	55(5608)	144(14686)	3500	55.3	28.93(2.95)	SH-21010	2.65(27.2)	HB12N1	-
MH-218	166.5	457 73	11.5	25	71(7240)	180(18355)	2000	170	174.6(17.8)	SYHL-2816	3.07(32)	HB15A1	-
MH-221	166.5	530 105	10.6	23	90(9177)	220(22460)	1700	228	342.1(34.7)	SYHL-2816	2.86(29.1)	HB18B2	-
MH-224	190	610 120	10.6	23	90(9177)	234(23861)	1400	293	651(66.4)	SHL-39024	1.57(16.1)	HB18B2	-

※ Maximum turning speed is based upon actual measurement.
※ Specifications are subject to change without notice.

※ Samcully Machinery Co., Ltd. is no longer an OEM manufacturer for Kitagawa® Iron Works Co., Ltd.

※ 最大转速基于实际测量。
※ 技术规格若发生改变, 恕不另行通知。
※ 三千里机械已结束与日本北川OEM生产。