

Y-RE 中实液压缸[带接近开关]

Closed-Center Hydraulic Cylinder with Proximity Bracket (75mm-125mm)

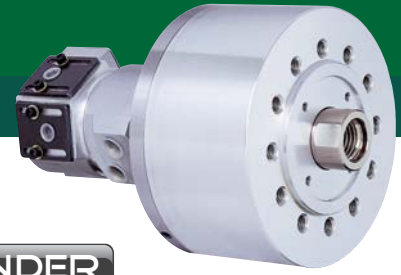

- Closed-centered hydraulic cylinder with built in lock and relief valves and proximity bracket

- 闭心式液压缸·带内置锁紧和泄放阀和接近开关

HYDRAULIC CYLINDER

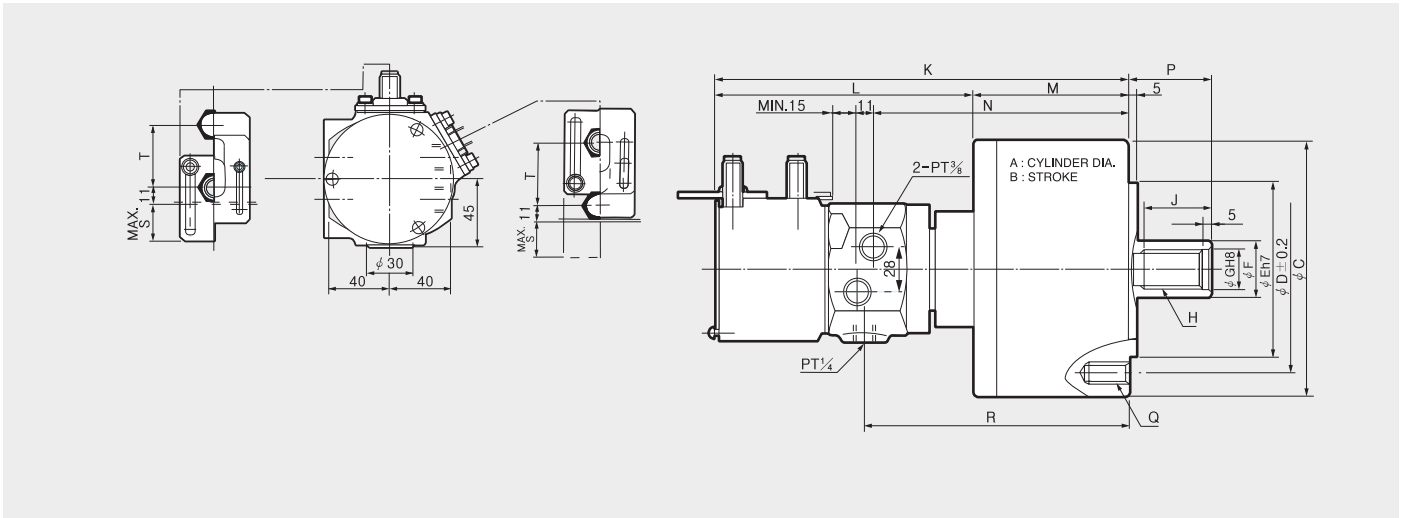

Dimensions / 치수표

	A	B	φC	φD	φE	φF	φG	H	J	K	L	M	N	Pmax.	Pmin.	Q	R	S	T
Y-0715RE	75	15	104	90	65	30	21	M20x2.5	32	227	161	66	127	46	31	6-M6x20	133	23	41
Y-1020RE	105	20	135	100	80	30	21	M20x2.5	35	252	163	89	152	45	25	6-M10x20	158	23	41
Y-1025RE	105	25	135	100	80	30	21	M20x2.5	35	257	163	94	157	45	20	6-M10x20	163	23	41
Y-1225RE	125	25	160	130	110	35	25	M24x3.0	44	260	163	97	160	51	26	6-M12x24	166	23	41
Y-1240RE	125	40	160	130	110	35	25	M24x3.0	44	306	194	112	175	65	25	6-M12x24	181	-	-

Specifications / 사양

Type	Piston Stroke 活塞行程 [mm]	Piston Surface Area 活塞表面积		Piston Force 活塞力		Max. Operating Pressure 最大工作压力 [MPa(kgf/cm ²)]	Max. r.p.m. 最大转速 [min ⁻¹]	GD ² 容许工作惯性 [N·m ² (kgf·cm ²)]	Weight 重量 [kgf]	Total leakage 总泄露 [l/min]	KITAGAWA® Model 北川型号
		Push [cm ²]	Pull [cm ²]	Push [kN(kgf)]	Pull [kN(kgf)]						
Y-0715RE	15	44	37	16.6(1693)	13.9(1417)	4.0(40.8)	6000	0.118(0.012)	4.5	0.8	Y-0715RE
Y-1020RE	20	84	79	32.0(3264)	29(2957)	4.0(40.8)	6000	0.46(0.05)	7.6	0.8	Y-1020RE
Y-1025RE	25	84	79	32.0(3264)	29(2957)	4.0(40.8)	6000	0.49(0.05)	7.7	0.8	Y-1025RE
Y-1225RE	25	120	113	46.0(4692)	42(4283)	4.0(40.8)	6000	0.88(0.09)	10.5	0.8	Y-1225RE
Y-1240RE	40	120	113	46.0(4692)	42(4283)	4.0(40.8)	6000	0.88(0.09)	11	0.8	Y-1240RE

※ Specifications are subject to change without notice.

※ Maximum turning speed is based upon actual measurement.

※ Piston Force : Hydraulic 4.0MPa (40.8kgf/cm²)

※ Total leakage pressure: 3.0 Mpa (30.6 kgf/cm²) at 50 ° C.

※ Samcully Machinery Co., Ltd, is no longer an OEM manufacturer for Kitagawa® Iron Works Co., Ltd

※ 最大转速基于实际测量。

※ 技术规格若发生改变,恕不另行通知。

※ 活塞力: 液压 4.0 Mpa (40.8 kgf/cm²)

※ 总Leak量是油压 3.0 Mpa (30.6 kgf/cm²), 总油温度 50 °C时。

※ 目前三千里机械已不再跟日本北川进行OEM生产。

Y-RE 中实液压缸 [带接近开关]

Closed-Center Hydraulic Cylinder with Proximity Bracket (150mm-250mm)

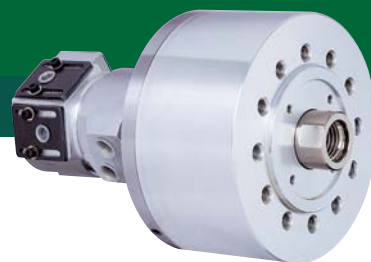

- Closed-centered hydraulic cylinder with built in lock and relief valves and and proximity bracket

- 闭心式液压缸·带内置锁紧和泄放阀和接近开关

HYDRAULIC CYLINDER

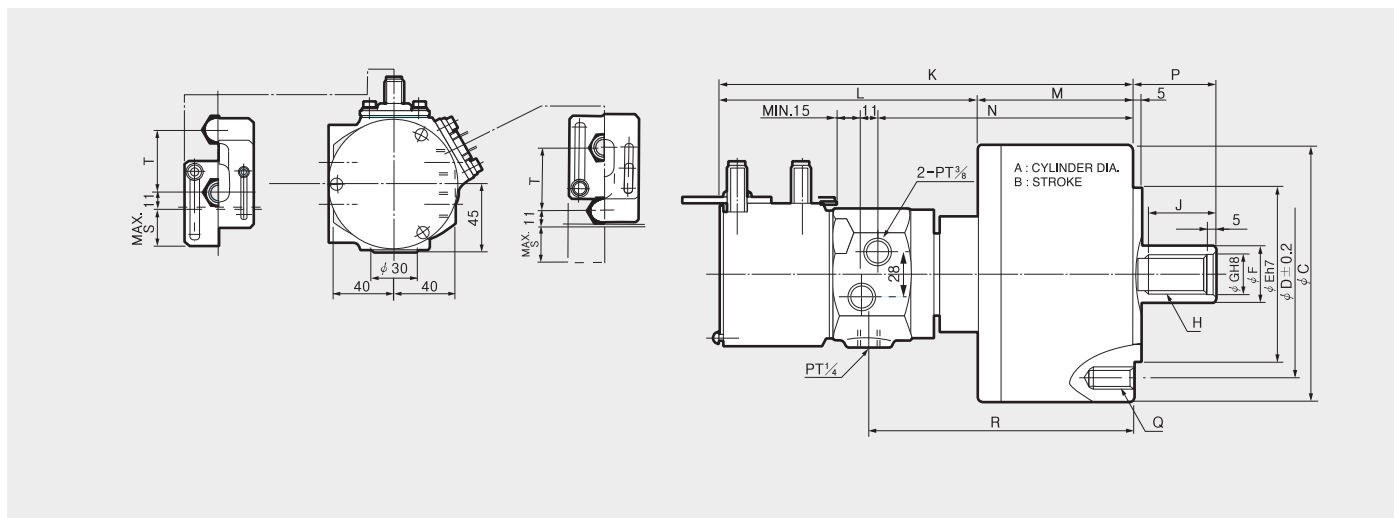

Dimensions

	A	B	ΦC	ΦD	ΦE	ΦF	ΦG	H	J	K	L	M	N	Pmax.	Pmin.	Q	R	S	T
Y-1530RE	150	30	190	130	110	45	31	M30x3.5	45	269	163	106	169	56	26	6-M12x24	175	23	41
Y-1550RE	150	50	190	130	110	45	31	M30x3.5	55	320	194	126	189	80	30	6-M12x24	195	-	-
Y-2035RE	200	35	245	145	120	55	37	M36x4.0	60	288	166	122	183	69	34	12-M16x30	189	28	46
Y-2050RE	200	50	245	145	120	55	37	M36x4.0	60	333	192	141	202	80	30	12-M16x30	208	-	-
Y-2560RE	250	60	305	220	160	65	44	M42x3.0	65	379	207	172	227	85	25	12-M20x35	233	-	-

Specifications

Type	Piston Stroke 活塞行程 [mm]	Piston Surface Area 活塞表面积		Piston Force 活塞力		Max. Operating Pressure 最大工作压力 [MPa(kgf/cm ²)]	Max. r.p.m. 最大转速 [min ⁻¹]	GD ² 容许工作惯性 [N·m ² (kgf·m ²)]	Weight 重量 [kgf]	Total leakage 总泄露 [l/min]	KITAGAWA® Model 北川型号
		Push [cm ²]	Pull [cm ²]	Push [kN(kgf)]	Pull [kN(kgf)]						
Y-1530RE	30	174	160	66.0(6732)	60(6118)	4.0(40.8)	5500	1.86(0.19)	14	0.8	Y-1530RE
Y-1550RE	50	174	160	66.0(6732)	60(6118)	4.0(40.8)	5500	1.96(0.20)	14.8	0.8	Y-1550RE
Y-2035RE	35	312	290	117.0(11934)	108(11013)	4.0(40.8)	5500	3.82(0.39)	22.5	0.8	Y-2035RE
Y-2050RE	50	312	290	117.0(11934)	108(11013)	4.0(40.8)	5500	4.12(0.42)	23.5	0.8	Y-2050RE
Y-2560RE	60	515	482	193(19541)	180(18289)	4.0(40.8)	2000	9.0(0.92)	85	0.8	-

※ Specifications are subject to change without notice.

※ Maximum turning speed is based upon actual measurement.

※ Piston Force : Hydraulic 4.0MPa (40.8kgf/cm²)

※ Total leakage pressure: 3.0 Mpa (30.6 kgf/cm²) at 50 °C.

※ Samcully Machinery Co., Ltd, is no longer an OEM manufacturer for Kitagawa® Iron Works Co., Ltd

※ 最大转速基于实际测量。

※ 技术规格若发生改变,恕不另行通知。

※ 活塞力: 液压 4.0 Mpa (40.8 kgf/cm²)

※ 总Leak量是油压 3.0 MPa (30.6 kgf/cm²), 总油温度 50 °C时。

※ 目前三千里机械已不再跟日本北川进行OEM生产。