

SYH 标准中空液压缸

Standard Open-Center Hydraulic Cylinder

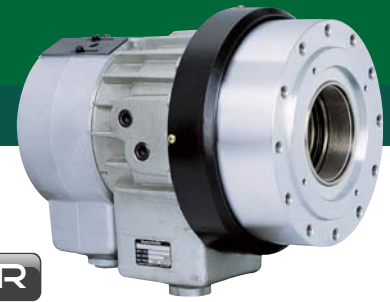

- High-speed open-centered hydraulic cylinder with built-in lock and relief valves

- 高速开中心式液压缸·带内置锁紧和泄放阀

HYDRAULIC CYLINDER

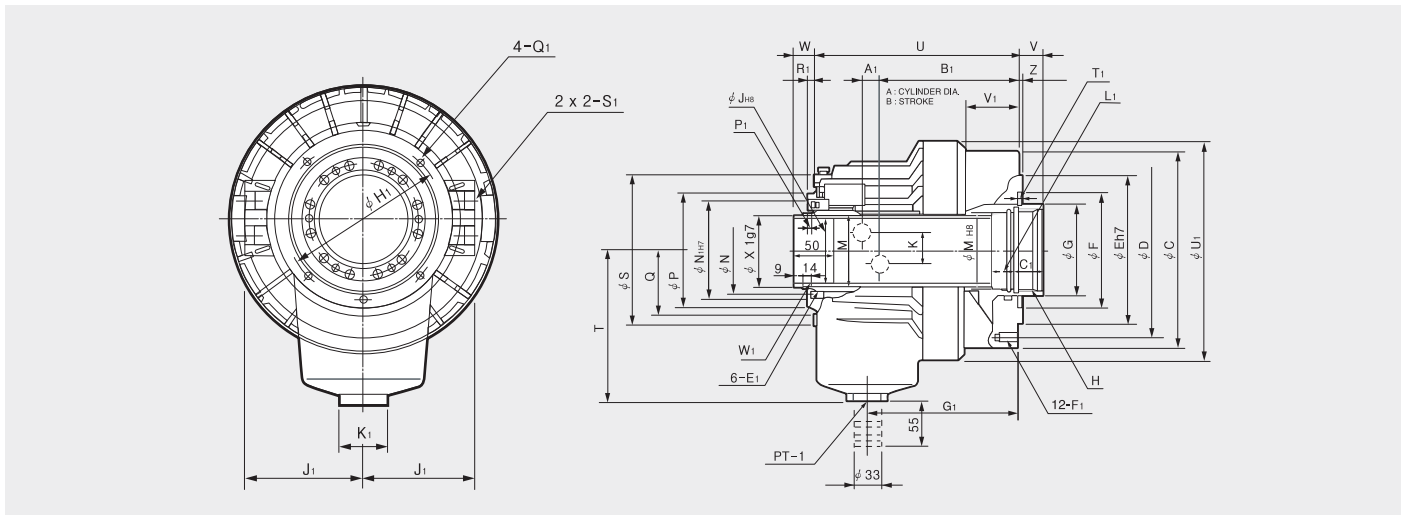

Dimensions

	ΦC	ΦD	ΦE	ΦF	ΦG	Hmax.	ΦJ	K	ΦM	ΦN	ΦP	Q	ΦS	T	U	Vmax.	Vmin.	Wmax.	Wmin.	Z	A1
SYH-1036	135	115	100	65	48	M42x1.5	36	30	44.6	55	73	45	104	115	156	15	0	40	25	5	11
SYH-1246	155	130	100	80	65	M52x2.0	46	36	52.9	64	85	51.5	118	115	184	15	0	40	25	5	11.5
SYH-1552	190	170	130	85	70	M60x2.0	52	36	59.6	73	96	57	137	130	191	22	0	47	25	5	12
SYH-1877	215	190	160	120	95	M85x2.0	77	36	84.6	98	121	70	166	160	230	25	0	50	25	5	17.5
SYH-2091	240	215	180	140	110	M100x2.0	91	34	99.6	108	138	79	182	185	253	30	0	55	25	5	21

	B1	C1	E1	F1	G1	H1	J1	K1	L1	M1	ΦN1	P1	Q1	R1	S1	T1	ΦU1	V1	W1	ΦX1
SYH-1036	102.5	25	M5x11	6-M10x17	98	88	73	47	15	38	64	4	M5x10	5	PT3/8	6	158	28	M44x1.5	42
SYH-1246	126.5	30	M6x9	12-M10x20	135	98	76	47	15	50	76	4	M5x10	6	PT1/2	6	200	46	M52x1.5	50
SYH-1552	136	30	M6x9	12-M10x20	145	110	86	47	15	55	85	4	M6x12	7	PT1/2	6	220	51	M58x1.5	56
SYH-1877	153.5	35	M6x9	12-M10x20	166.5	155	101	47	15	80	108	4	M6x12	7	PT1/2	6	242	58	M84x2.0	81
SYH-2091	168	35	M6x14	12-M12x24	183	165	110	47	15	95	120	4	M6x12	7	PT1/2	6	267	66	M99x2.0	96

Specifications

Type	Available I.D. 可用内径 [mm]	Cylinder Dia. 缸径 [mm]	Piston Stroke 活塞行程 [mm]	Piston Surface Area 活塞表面积		Piston Force 活塞力		Max. Operating Pressure 最大工作压力 [MPa(kgf/cm ²)]	Max. r.p.m. 最大转速 [min ⁻¹]	GD ² 容许工作惯性 [N·m ² (kgf·m ²)]	Weight 重量 [kgf]	Total leakage 总泄露 [l/min]	KITAGAWA® Model 北川型号
				Push [cm ²]	Pull [cm ²]	Push [kN(kgf)]	Pull [kN(kgf)]						
SYH-1036	36	105	15	67	64.5	25(2549)	24(2447)	4.0(40.8)	8000	0.10(0.011)	8.6	3	S-1036
SYH-1246	36,39,40,41,43,45,46	125	15	100	89	38(3875)	33(3365)	4.0(40.8)	8000	0.18(0.019)	12	3	S-1246
SYH-1552	46,52,69	155	22	161	150	60(6118)	56(5710)	4.0(40.8)	6200	0.52(0.053)	16.8	3.9	S-1552
SYH-1877	68,69,75,77	180	25	198	183	74(7546)	69(7036)	4.0(40.8)	4700	0.93(0.095)	26	4.2	S-1875
SYH-2091	78,91	205	30	252	234	94(9584)	88(8973)	4.0(40.8)	3800	1.45(0.153)	33	4.5	S-2091

※ Specifications are subject to change without notice.
 ※ Maximum turning speed is based upon actual measurement.

※ 技术规格若发生改变,恕不另行通知。
 ※ 最大转速基于实际测量。